

nomon  
JEWELRY FOR HOME

We create jewelry for your home.  
Creamos joyas para tu hogar.



Nomon Culture  
P.4-P.5

Design & Tradition  
P.6-P.7

Momentos Collection  
P.10-P.53

Única Collection  
P.54-P.73

Escultura Collection  
P.74-87

Mixta Collection  
P.88-97

Technical Information  
P.100-P.111



Culture JEWELRY FOR HOME

UNIQUE CONCEPT Nomon Home fuses passion for jewelry and furniture design, creating an innovative project, where the complementary furniture becomes the main role with elegance, style and sophistication.

NUESTRO CONCEPTO Nomon Home fusiona la pasión por la joyería y el diseño de mobiliario, creando un proyecto innovador, donde el mueble complementario se convierte en el protagonista de la elegancia, el estilo y la sofisticación.



**NOMON STYLE** Our style and personality at Nomon disregards fashion and trends, achieving a unique and renowned identity which persists over time.

**ESTILO NOMON** El estilo y la personalidad de Nomon es ajena a las modas y las tendencias consiguiendo una identidad reconocible estable y con recorrido.

Design TRADITION AND CRAFTMANSHIP

NATURAL AND NOBEL We are faithful to noble materials, such as marble, natural walnut and brass; classics for our passion with craftsmanship, being able to combine romanticism and technology.

NATURALES Y NOBLES Somos fieles a los materiales nobles, el mármol, la madera y el metal y clásicos en nuestro amor por la artesanía, capaces de fusionar romanticismo y tecnología.







Designer **ANDRÉS MARTÍNEZ**

**ANDRÉS MARTÍNEZ** Born in Córdoba in a family with jewelry tradition; his creations are recognized with a true sense to noble materials and handcradts, searching the true luxury, yet timeless and minimal.

**ANDRÉS MARTÍNEZ** Nacido en Córdoba en el seno de una familia de tradición joyera, sus creaciones se reconocen por la fidelidad a los materiales nobles y la artesanía en la búsqueda del auténtico lujo sereno, contenido y atemporal.



Designer STEFANO BIGI

**STEFANO BIGI** Stefano Bigi grew up between France and Italy. Out of this double culture, he acquired a taste for the chic and the beautiful. Studying at Art School, he specialized in design furniture, contributing a sculptural concept, fusion between art and object. Recognizable designs with great presence, artwork pieces worth of any gallery.

**STEFANO BIGI** Stefano Bigi es de origen francés y educado en Italia, lo que marca su estilo chic y elegante. Finalizados sus estudios en la Escuela de Arte se especializó en el diseño de mobiliario, aportando un concepto escultórico, fusión entre el arte y el objeto. Piezas reconocibles de gran presencia, obras de arte dignas de coleccionista.

Collection MOMENTOS

Designed by Andrés Martínez. Seductive objects which transform our daily life aspects into luxurious moments, functional pieces providing pleasant sensations of well-being.

Diseñada por Andrés Martínez. Objetos seductores que transforman aspectos de nuestra vida cotidiana en momentos de bienestar, piezas funcionales que nos hacen la vida más agradable.





Momentos TOCADOR

Sophisticated Tocador (vanity table) inspired in a sensible woman.

\*Finish in black stained ash with Sahara Noir marble.

Sofisticado Tocador inspirado en una mujer sensible.

\*Acabado en fresno negro con mármol Sahara Noir.







Its jewelry box and softness shapes allure femininity to the design. Accompanied by a pouf/ottoman upholstered in velvet and silk trimming.  
\* Finish in natural walnut and upholstered in beige velvet.

La original cajita joyero y la suavidad de sus formas le aportan feminidad. Le acompaña un pouf tapizado en terciopelo con pasamanería de seda.  
\*Acabado en nogal natural y pouf tapizado beige.











Momentos MESA VAIVÉN

Attractive side table with a functional swivel top.

Mesa atractiva y funcional gracias al movimiento giratorio de sus sobres.



Its subtle wood turning lathe holding the superior top creates a visual element with balance and lightness.

The marble base contributes with prestige to the design.

El sutil torneado que sostiene el sobre superior crea un juego visual de equilibrio y ligereza.

El mármol de la base aporta prestigio a la pieza.





Momentos RECIBIDOR

Furniture for Hallway or Dressing areas, to place your keys and accessories when arriving home.

Mueble de recibidor o vestidor, donde dejar las llaves y accesorios al llegar a casa.









Timeless piece due to its minimalist and warm design. The original gold rod sophisticates the traditionality of the piece.

Pieza atemporal gracias a su diseño minimalista y cálido. La original varilla llavero sofisticada su funcionalidad.



Momentos GALÁN W  
Jewelry furniture for your dressing space.  
Su diseño lo convierte en una joya para nuestro vestidor.







Its innovative design integrates a whimsical jewelry box made of polished brass and a natural walnut shelf.  
El original diseño integra un coqueto joyero de latón pulido con una bandeja de nogal natural.



Momentos GALÁN M

We have recovered the valet stand updating the piece and renewing its functionality.  
Recuperamos el galán actualizando la pieza y renovando su funcionalidad.









New concept of the classic suit valet, a seductive object that transforms our daily life.  
Es un concepto nuevo del clásico galán de noche, un objeto seductor que transforma nuestra vida diaria.

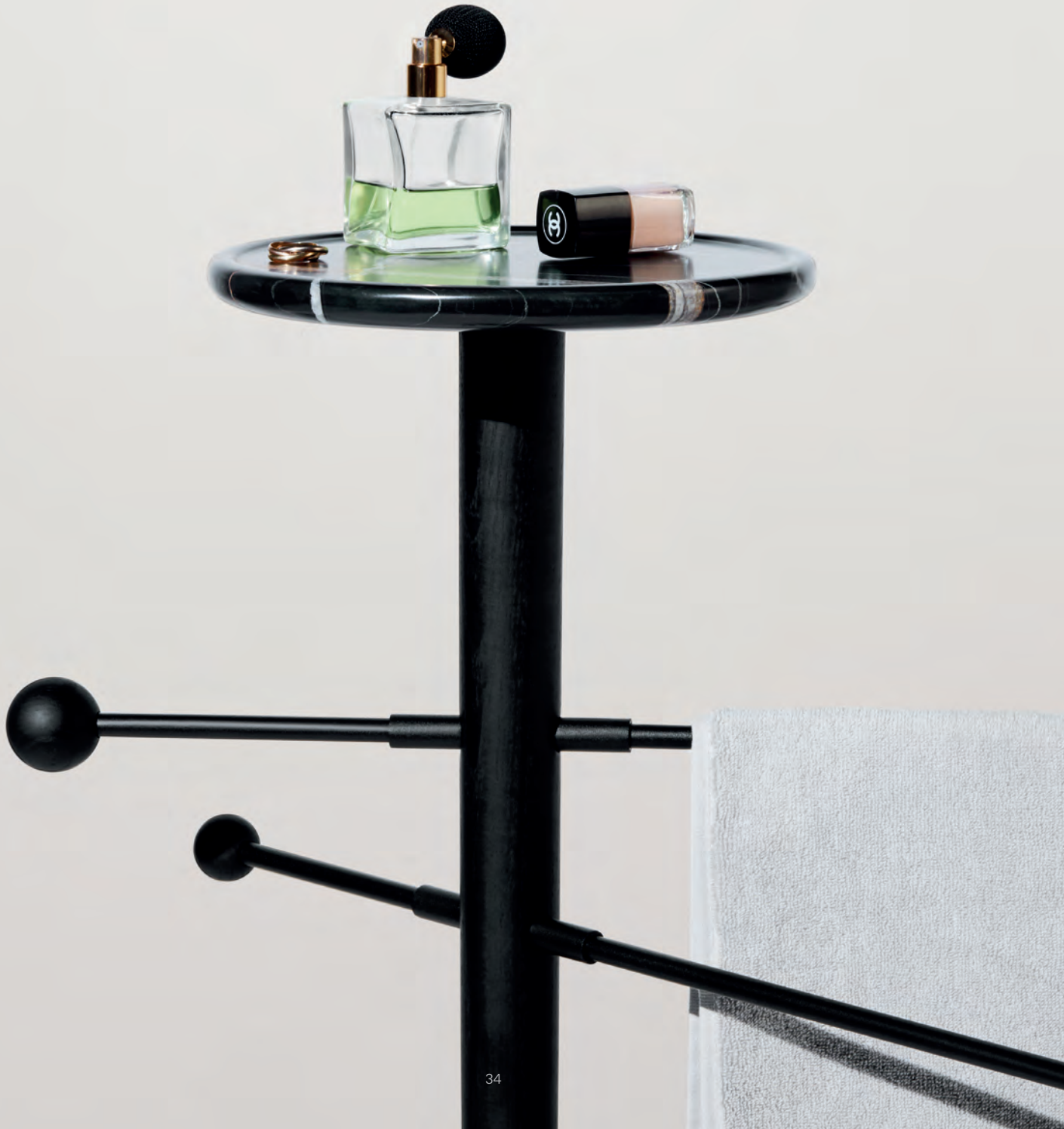



Momentos TOALLERO

Towel stand inspired in the art gallery pedestals.  
Toallero inspirado en los pedestales de las galerías de arte.



Towel stand with a subtle and delicate design that sophisticates your bathroom.

Toallero sutil y delicado que sofistica la zona de baño.







Momentos BAR

We create a space to enjoy a drink in good company.  
Creamos un espacio para beber en buena compañía.





Marble top and suspended glasses from the Golden rods evoke classical bar cabinets.  
La barra de mármol y las copas suspendidas de las varillas doradas evocan a las coctelerías clásicas.



Singular design to complement your dining décor.  
Mini bar que complementa la zona de comedor.





Momentos CHAMPAGNERA

A unique piece to enjoy at home or in your favourite restaurant.  
Una pieza única para disfrutar en casa o en tu restaurante favorito.





Momentos CONSOLA  
Simplicity is the essence of its appeal.  
La sencillez es la esencia de su atractivo.



Emperador marble is a natural stone, elegant and exquisite with ranging tones from pearl to chocolate.

El mármol Emperador es una piedra natural, exquisita y elegante con distintos tonos desde el perla hasta el chocolate.







Momentos MESITA M

Versatile and contemporary design to complement a sofa or as night-side table

\*Finish in natural walnut and Calacatta Gold marble.

Diseño versátil y contemporáneo ideal junto al sofá o como mesita de noche.

\*Acabado nogal natural con mármol Calacatta gold.







Momentos ESPEJO

The singularity of this mirror is based on its caring proportions.  
La singularidad de este espejo recae en sus cuidadas proporciones.





Two options with floor-standing mirror or wall-mirror ; a hand-made natural walnut shelf combines the softness lines of the mirror.

El espejo de pie o de pared destaca por la original bandejita de nogal natural de líneas suaves realizada a mano.

Collection ÚNICA

Designed by Andrés Martínez. Única collection is born with the aim of the user to participate in the design of the furniture, offering in a simple and intuitive way infinite possibilities.

Diseñada por Andrés Martínez. La colección Única nace con el objetivo de que el usuario participe en el diseño del mobiliario, ofreciendo de un modo simple e intuitivo infinitas posibilidades.









### Única ESTANTERÍA

Functional system to adapt your design needs transforming the space.  
Sistema funcional que se adapta a tus necesidades transformando el espacio.





**Simplicity of design and easy installation.**  
Destaca la simplicidad de su diseño y la fácil instalación.

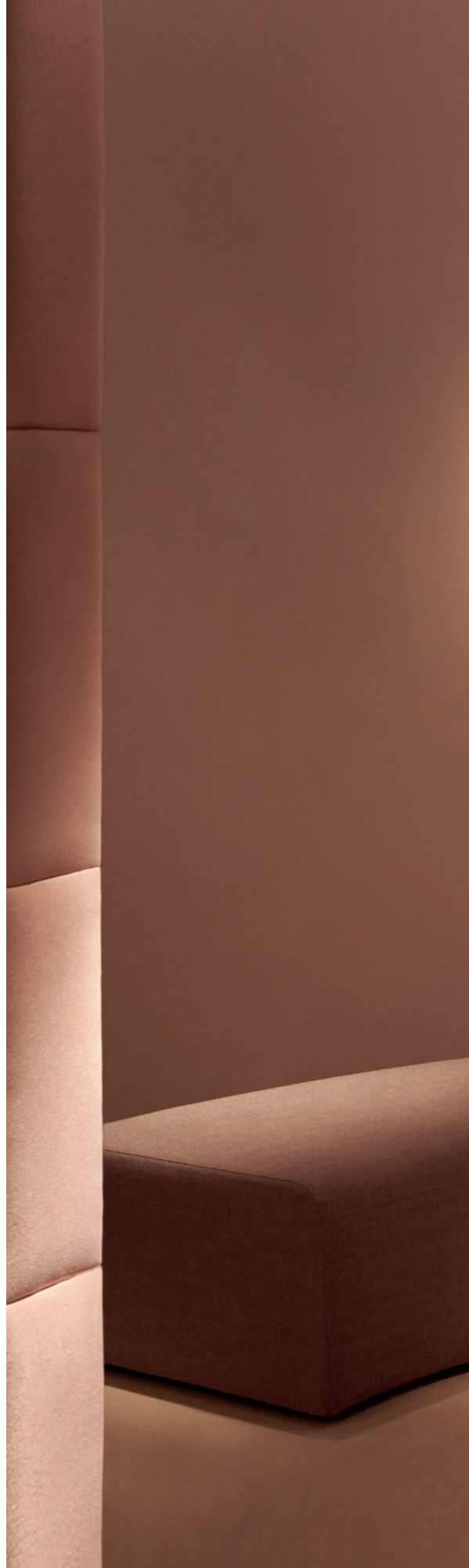

Contemporary classicism in its design and exquisite artisan execution provide elegance, warmth and serenity to this piece.

El clasicismo contemporáneo de su diseño y la exquisita ejecución artesanal le aportan elegancia, calidez y serenidad.





The system can also be adapted to corner installations.  
Sorprende la capacidad del sistema que se adapta a la instalación en esquina.



Natural walnut has an important role in aesthetic and is related to tradition, truth and honesty.

El nogal natural tiene un papel importante en la estética y se relaciona con la tradición,  
la verdad y la honestidad.



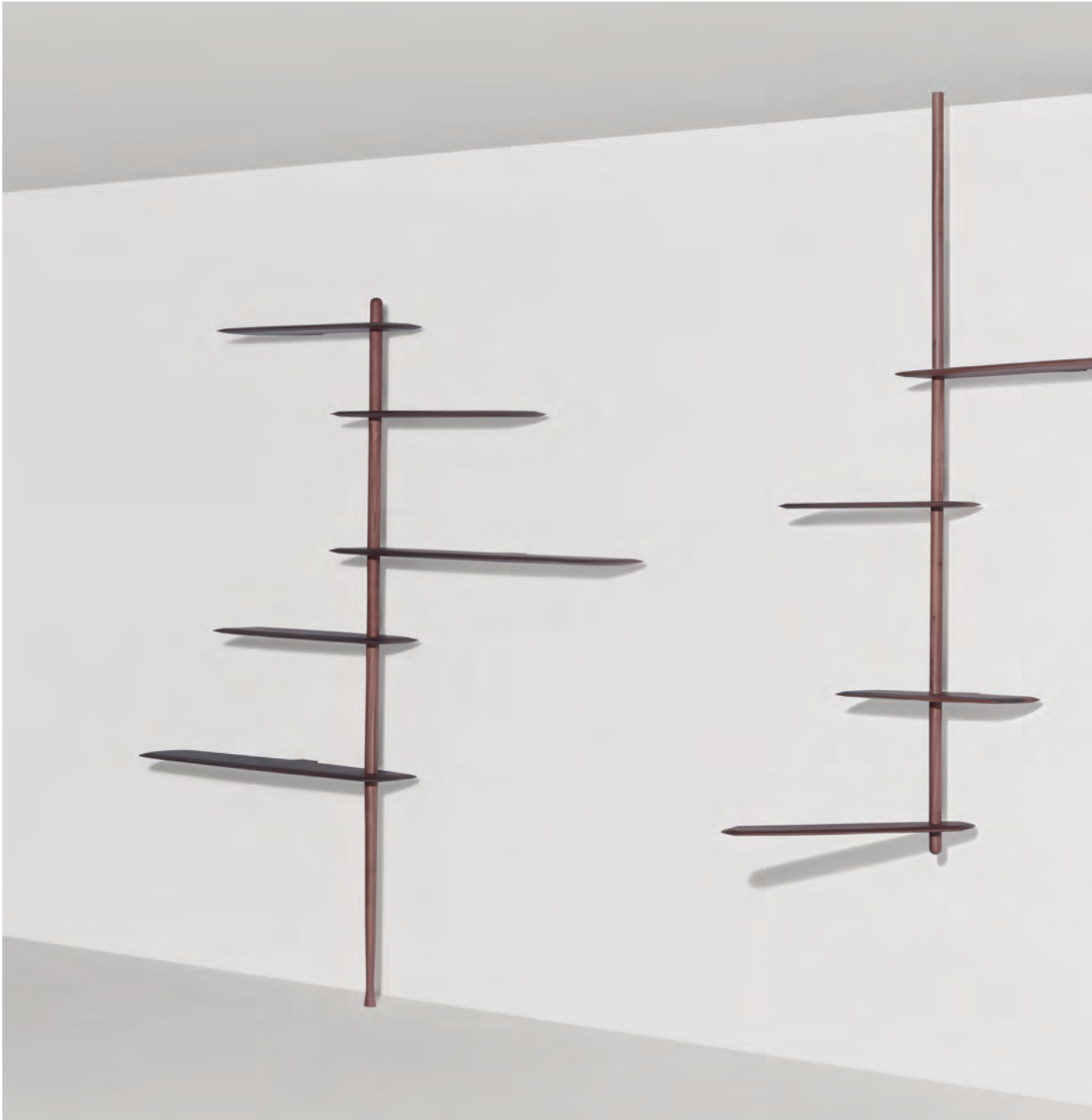

#### UNICA SYSTEM

Modular structures in which you can design the shelving system combining shelves and rods of different dimensions.

#### SISTEMA UNICA

Es un sistema modular que permite configurar estanterías a medida combinando baldas y tramos de distintas dimensiones.



#### 1. FLOOR OR CEILING INSTALLATION

It can be installed on the floor or suspended from the ceiling, alternating freestanding and fixed shelves.

#### 1. INSTALACIÓN A SUELO O A TECHO

Permite la instalación desde el suelo o fijada al techo, alternando baldas fijas a pared o libres.

#### 2. FRONT OR CORNER SHELVING

Allows installation on several positions, combining with flat angled walls.

#### 2. ESTANTERÍA FRONTAL O ESQUINA

Posibilidad de instalación en cualquier posición, ya sea en una pared plana o una esquina abierta o cerrada.

#### 3. FREESTANDING SHELF

The system allows alternating fixed and freestanding shelves, which can rotate, providing additional functionality.

#### 3. BALDA MÓVIL

El sistema permite alternar baldas fijas a pared y libres que pueden girar, dotándolo de mayor funcionalidad.





Única ÚNICA MESA

Surprising by long proportions and the layout of its walnut legs in diamond-shape.  
Sorprenden sus proporciones y la disposición en forma de rombo de sus patas de madera torneada.

Organic design, subtle and essential.  
Discreet in height and monochromatic  
finish in black or natural walnut.

Diseño orgánico, sutil y esencial. Discreta  
en su altura y acabado monocromático  
negro o nogal.









Única ESCRITORIO

A contemporary and classic space to be inspired.  
Un contemporáneo y exquisito lugar donde inspirarse.







### Única ESCRITORIO

Escritorio allows to combine fixed and freestanding shelves, which can rotate, providing additional functionality.

El Escritorio alterna baldas fijas a pared y baldas libres que pueden girar, dotándolo de mayor funcionalidad.

Collection ESCULTURA

Designed by Stefano Bigi. A sculpture made by craftsmen, whose hands embrace a luxury touch.

Diseñada por Stefano Bigi. Una escultura realizada por artesanos, donde la caricia de una mano le aporta un toque de lujo.

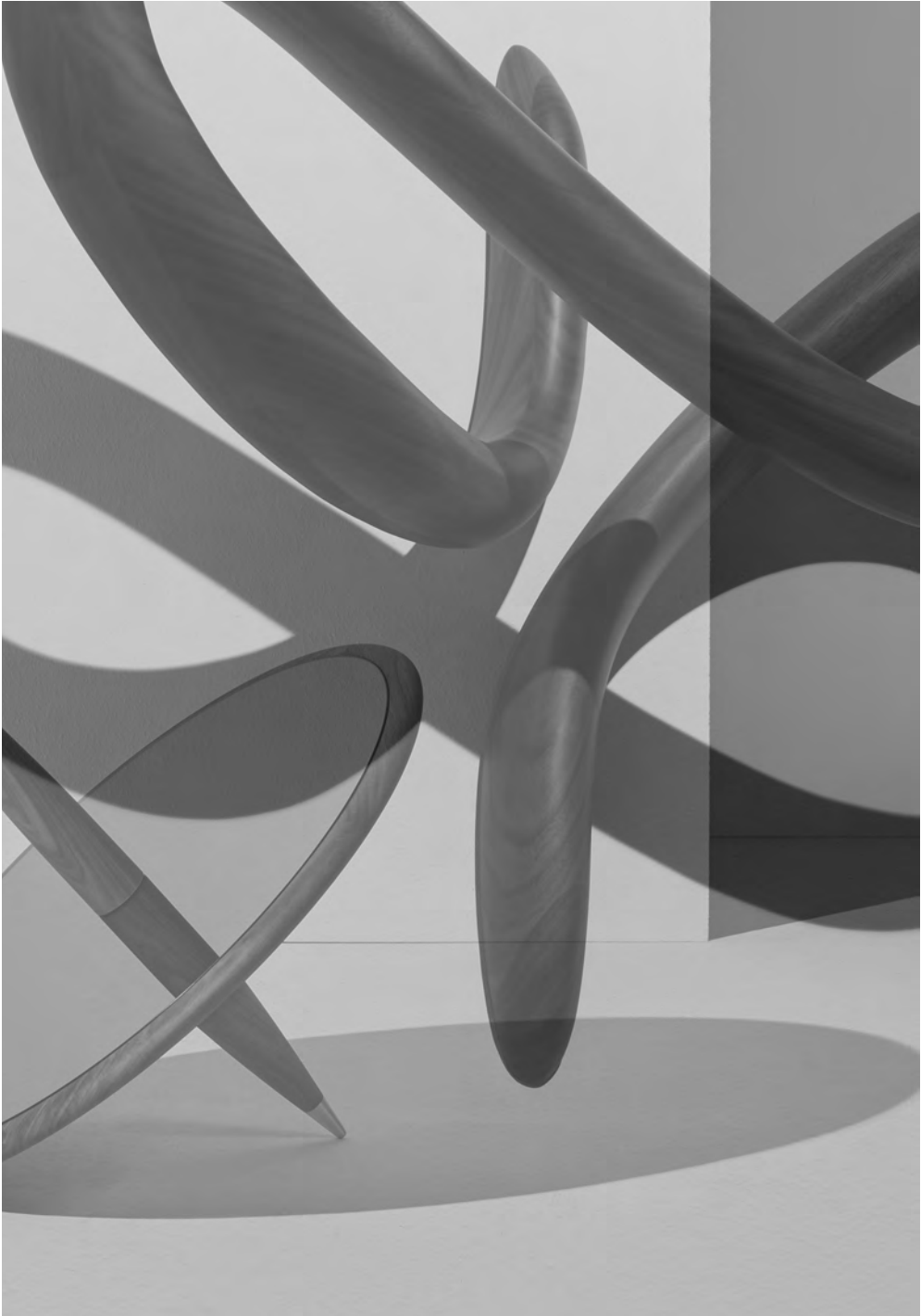





Escultura ASTRO

Eclectic floor lamp, fusing tradition and innovation into modern design.  
Ecléctica lámpara de suelo, cuya fusión entre tradición e innovación la convierten  
en extremadamente moderna.



Indirect lighting to create a warm atmosphere which allures wellness.  
La iluminación indirecta crea una atmósfera cálida que nos aporta bienestar.







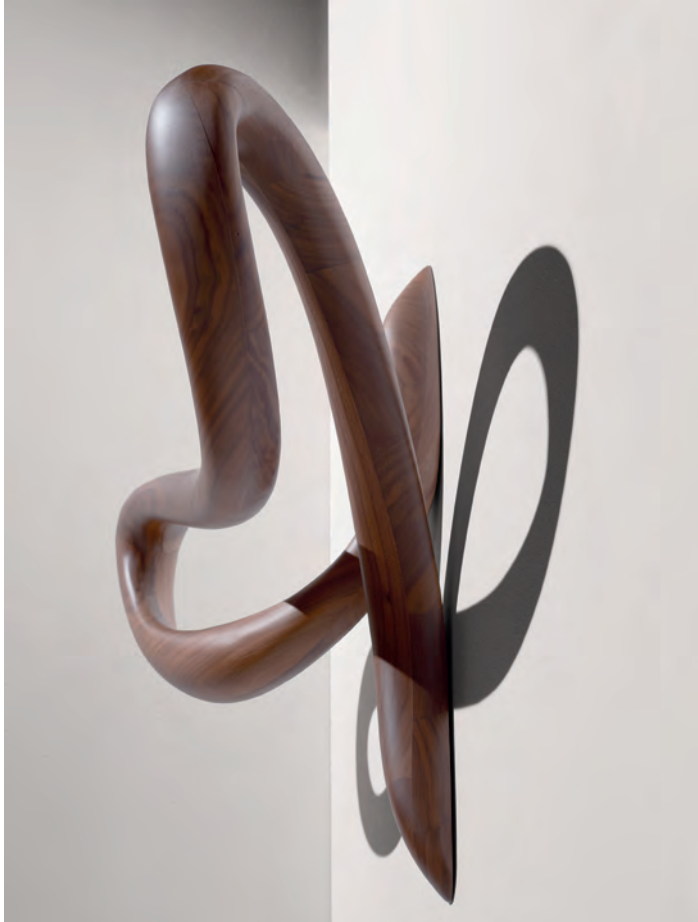

Escultura VERTIGO

Timeless sculpture, its aesthetic function expresses a unique lifestyle.  
Atemporal pieza escultórica, su función estética expresa un estilo de vida.









Escultura PEONZA

Tribute to the spinning top and childhood games.  
Homenaje a la peonza y juegos de la infancia.





Our Spinning Top is also a whimsical floor mirror.  
La Peonza funciona como un divertido espejo de suelo.



Collection MIXTA

Its compelling design provides configurations of side tables with different dimensions combining natural walnut with marble – Calacatta Gold, Sahara Noir or Emperador.

Su atractivo diseño permite configurar mesas de diferentes dimensiones combinando nogal con mármoles Calacatta Gold, Sahara Noir o Emperador.







Mixta MESA MIXTA TRIO

When design invites you to participate in its creation.  
In this configuration the central element is with Sahara Noir marble.  
Su diseño invita a participar en la creación.  
En esta ocasión con el elemento central en mármol Sahara Noir.









Mixta MESA MIXTA DÚO

Elegant table with a strong personality and big presence which will not go unnoticed.  
Elegante mesa de fuerte personalidad y gran presencia que no pasará desapercibida.





Mixta MESA MIXTA DÚO

Sophisticated and versatile due to the combination of walnut and marble.

Sofisticada y versátil gracias al juego del nogal y el mármol.





Momentos Tocador  
P.12-17



Momentos Mesa Vaiven  
P.18-21



Momentos Recibidor  
P.22-25



Momentos Galan W  
P.26-29



Momentos Galan M  
P.30-33



Momentos Toallero  
P.34-37



Momentos Bar  
P.38-40



Momentos Champagnera  
P.41-43



Momentos Consola  
P.45-47



Momentos Mesita  
P.48-49



Momentos Espejo  
P.50-53



Única Estanteria  
P.56-65



Única Mesa  
P.66-69



Momentos Espejo  
P.70-73



Escultura Astro  
P.76-79



Escultura Vértigo  
P.80-83



Escultura Peonza  
P.84-87



Novedades Mesa Mixta  
P.90-97

PACKAGING

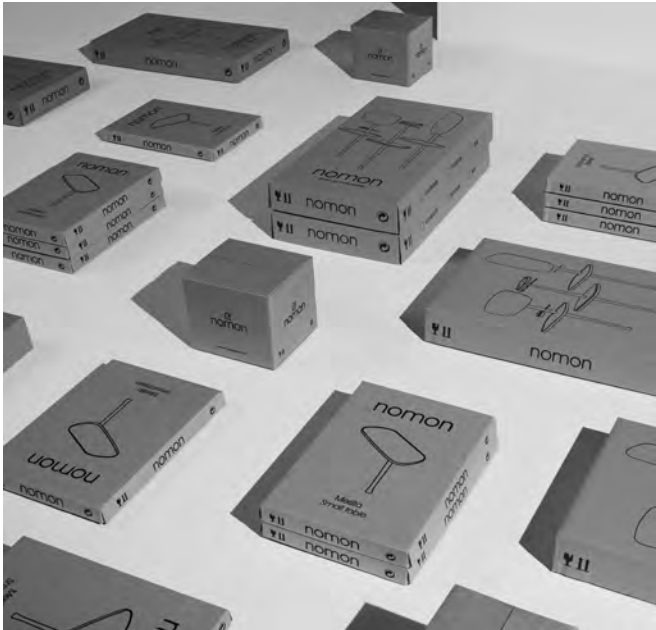

## PACKAGING

Our packaging is made of kraft cardboard with an interior foam lining that provides security and lightness for air shipments. The boxes show jewelry interior presentation and design.

Nuestro packaging está fabricado en cartón Kraft con revestimiento interior de espuma que le aporta ligereza y seguridad para envíos aéreos. Diseño y presentación de joyería.

## SHIPPING

**ESPAÑA** Transporte gratuito para pedidos superiores a 180€. Para pedidos inferiores a 180€, coste 12,40€ (IVA no incluido, 15€ IVA incluido).

**EUROPEAN UNION** Free on orders of over 500€ (excepting to Malta, Croatia and Cyprus). 30€ on orders under 500 € (specific transport quotation available for orders to the countries mentioned).

**REST OF THE WORLD** Ex-works conditions.

Specific airfreight transport quotation for your order is available. Consolidation of the order at your warehouse, within the European Union, free on orders over 500 €.

## DELIVERY TIME

**PLACE YOUR ORDER** Place your order through our stores, phone or website, consult our office for any specific information.

**QUOTATION** Right after placing your order by the media chosen you will receive the quotation by an email.

**PAYMENT** Make the payment following the instructions that you will find in the quotation.

**A WEEK AFTER** In only seven days you will receive your new product ready to furnish your home.

## TECHNICAL INFORMATION

## RECIBIDOR Hallway Furniture

MODEL	REF.
Recibidor Nogal/Walnut	CON
Recibidor Nogal/Mármol Emperador Hallway Walnut/Emperador marble	CONME
Recibidor Fresno Negro/Sahara Noir Hallway Black Ash/Sahara Noir	COBMS

\* El espejo puede ajustarse a dos alturas y a dos posiciones:

\* Mirror can be adjusted in two heights and two positions:

Vertical mirror · 172 / 180 cm Horizontal mirror · 157 / 164 cm

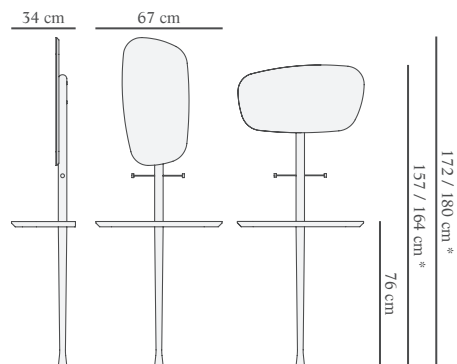

## TOCADOR Vanity table

MODEL	REF.
Tocador Nogal/Walnut	TON
Tocador Nogal/ Mármol Emperador Vanity Walnut/Emperador marble marble	TONME
Tocador Fresno Negro/Sahara Noir Vanity Black Ash/Sahara Noir	TOBMS

Material: Nogal natural o fresno teñido negro y detalles de latón pulido.

Material: Natural walnut or black stained ash and polished brass accessory.

Mármoles en stock: Emperador, Sahara Noir y Calacatta Gold.

Marbles in stock: Emperador, Sahara Noir and Calacatta Gold.

MODEL	REF.
Puf terciopelo rosa Pouf blush pink velvet	PTTR08
Puf terciopelo gris Pouf pewter grey velvet	PTTG10
Puf terciopelo crema Pouf sesame cream velvet	PTTC17
Puf tela cliente Pouf client's fabric	PTC

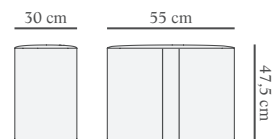
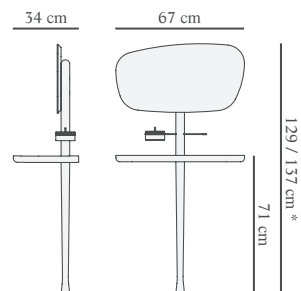

\*Posibilidad de usar tela cliente:  
Dimensiones tela: 1,40 m de ancho por 1,80 m de largo para 1 y 2 pufs.  
Possibility to use client fabric:  
Fabric dimensions: 1,40 m wide by 1,80 m long for 1 and 2 poufs.

## BAR Bar cabinet

MODEL	REF.
Bar Nogal/Mármol Emperador Bar Walnut/Emperador marble	BNMG
Bar Fresno negro/Sahara Noir Bar Black ash/Sahara Noir	BBMSG

Material: Nogal natural o fresno teñido negro y detalles de latón pulido.

Material: Natural walnut or black stained ash and polished brass accessory.

Mármoles en stock: Emperador, Sahara Noir y Calacatta Gold.

Marbles in stock: Emperador, Sahara Noir and Calacatta Gold.

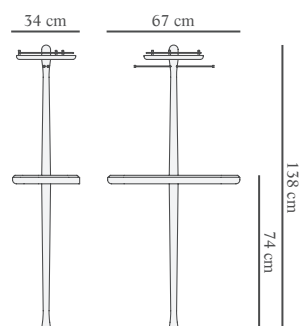

## CHAMPAGNERA Champagne bucket

MODEL	REF.
Champagnera G	CHNMD
Champagnera T	CHNMT

Material: Nogal natural o fresno teñido negro, cubitera de cristal y base de mármol.

Material: Natural walnut or black stained ash, crystal ice bucket and marble base.

Mármoles en stock: Emperador, Sahara Noir y Calacatta Gold.

Marbles in stock: Emperador, Sahara Noir and Calacatta Gold.

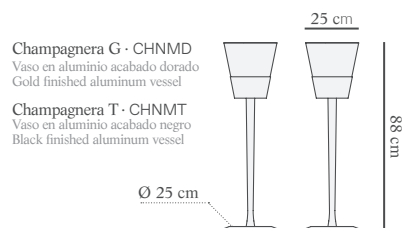



## GALÁN M Valet Stand M

MODEL	REF.
Galán M Nogal / Grafito / Mármol Emperador Galán M Walnut / Graphite / Emperador marble	GANMNTM
Galán M Fresno teñido negro / Grafito / Mármol Sahara Noir Galán M Black stained ash / Graphite / Sahara Noir marble	GANMBTSA

Base: Mármol

Conjunto: Nogal natural macizo o fresno teñido negro

Accesorios: Latón pulido o acabado grafito

Percha: Nogal natural, fabricada por Toscanini

Base: Marble

Set: Natural solid walnut or black stained ash

Accessories: Polished brass or graphite finish

Hanger: Solid walnut, manufactured by Toscanini

Mármoles en stock: Emperador, Sahara Noir y Calacatta Gold.

Marbles in stock: Emperador, Sahara Noir and Calacatta Gold.

Opción piezas metálicas doradas.

Optional metal parts in gold finish

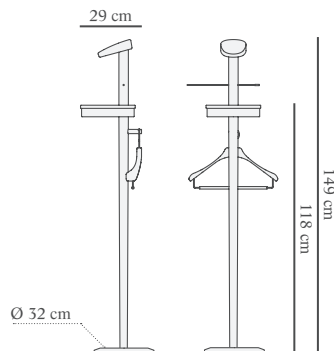

## GALÁN W Valet Stand W

MODEL	REF.
Galán W Nogal / Dorado / Mármol Emperador Galán W Walnut / Gold / Emperador marble	GANFNGEM
Galán W Fresno teñido negro / Dorado / Mármol Sahara Noir Galán W Black stained ash / Gold / Sahara Noir marble	GANFBGSA

Base: Mármol

Conjunto: Nogal natural macizo o fresno teñido negro

Accesorios: Latón pulido o acabado grafito

Percha: Nogal natural, fabricada por Toscanini

Base: Marble

Set: Natural solid walnut or black stained ash

Accessories: Polished brass or graphite finish

Hanger: Solid walnut, manufactured by Toscanini

Mármoles en stock: Emperador, Sahara Noir y Calacatta Gold.

Marbles in stock: Emperador, Sahara Noir and Calacatta Gold.

Opción piezas metálicas grafito.

Optional metal parts in graphite finish

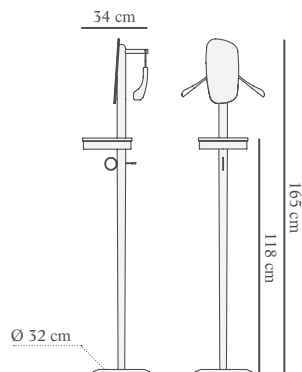

## TOALLERO Towel Stand

MODEL	REF.
Toallero Nogal / Mármol Emperador Towel stand N Walnut / Emperador marble	TOANE
Toallero Fresno teñido negro / Mármol Sahara Noir Towel stand Black stained ash / Sahara Noir marble	TOABS

Base y bandeja: Mármol

Conjunto: Nogal natural macizo o fresno teñido negro

Varillas: Latón pulido o latón pintado negro

Base and plate: Marble

Set: Natural solid walnut or black stained ash

Rods: Polished brass or brass painted in black

Mármoles en stock: Emperador, Sahara Noir y Calacatta Gold.

Marbles in stock: Emperador, Sahara Noir and Calacatta Gold.

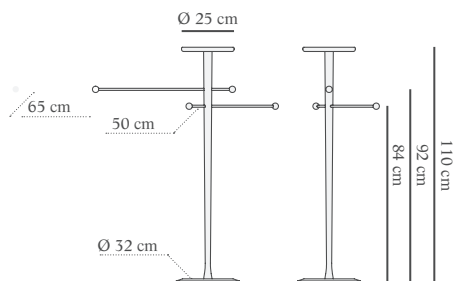

## ESPEJO PIE Floor Mirror

MODEL	REF.
Espejo de Pie Nogal / Mármol Emperador Floor Mirror Walnut / Emperador marble	ESPFNE
Espejo de Pie Fresno teñido negro / Mármol Sahara Noir Floor Mirror Black stained ash / Sahara Noir marble	ESPFBS

Base: Mármol

Conjunto: Nogal natural macizo o fresno teñido negro

Base: Marble

Set: Natural solid walnut or black stained ash

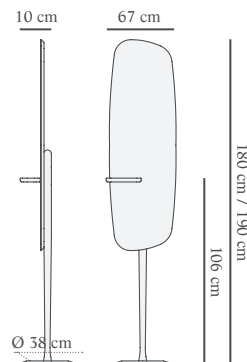

## ESPEJO DE PARED Wall Mirror

MODEL	REF.
Espejo Pared Nogal Wall Mirror Walnut	ESPWN
Espejo Pared Fresno teñido negro Wall Mirror Black stained ash	ESPWB

Conjunto: Nogal natural macizo o fresno teñido negro

Set: Natural solid walnut or black stained ash

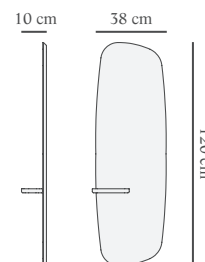

## CONSOLA Console table

MODEL	REF.
Consola Nogal / Walnut	CN
Consola Nogal / Mármol Emperador Console Walnut / Emperador marble	CNM
Consola Fresno Negro / Sahara Noir Console Black Ash / Sahara Noir	CNBM

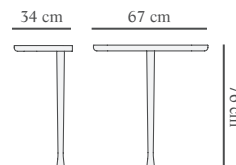

## MESITA S & M Table S & M

MODEL	REF.
Mesita S / Nogal Table S / Walnut	MES
Mesita M / Nogal Table M / Walnut	MEM
Mesita M Nogal / Mármol Emperador Table M Walnut / Emperador marble	MEMM

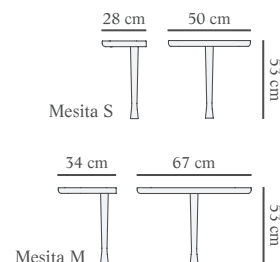

## MESA VAIVÉN Vaivén Side Table

MODEL	REF.
Mesa Vaivén N Nogal / Mármol Emperador Vaiven table N Walnut / Emperador marble	VANME
Mesa Vaivén B Fresno teñido negro / Mármol Sahara Noir Vaiven table B Black stained ash / Sahara Noir marble	VABMS

Material: Nogal natural o fresno teñido negro.

Material: Natural walnut or black stained ash veneered.

Mármoles en stock: Emperador, Sahara Noir y Calacatta Gold.

Marbles in stock: Emperador, Sahara Noir and Calacatta Gold.

El sobre superior permite un movimiento circular para adaptar la mesa a cualquier posición.

The upper top allows a circular movement to adapt the table to any position.

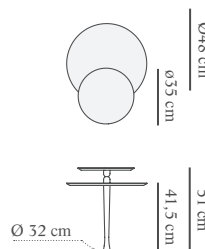

## ESTANTERÍA ÚNICA Única shelf system

### TRAMOS Y TERMINALES RODS & TERMINALS

MODEL	REF.
Tramo en Nogal natural Rod in natural solid walnut	ROD

- 1 · Pata/Leg 40 cm · Ø4cm
- 2 · Pata/Leg 70 cm · Ø4cm
- 3 · Tramo/Rod 25 cm · Ø4cm
- 4 · Tramo/Rod 40 cm · Ø4cm
- 5 · Tramo/Rod 60 cm · Ø4cm
- 6 · Tramo/Rod 80 cm · Ø4cm
- 7 · Tramo/Rod 120 cm · Ø4cm
- 8 · Terminal 8 cm · Ø4cm

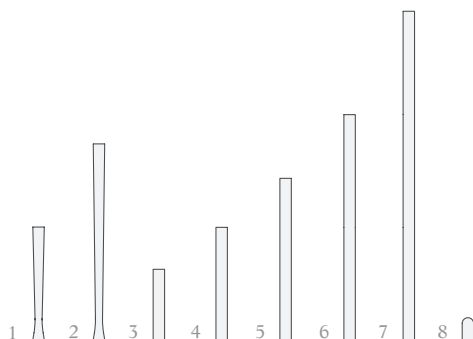

### BALDAS SHELVES

Longitud / Length: 82 cm - 122 cm  
Ancho / Width: 30 cm  
Grosor / Thickness: 1,8 cm

MODEL	REF.
S Air central Nogal natural macizo / Natural solid walnut	UBNSAC
S Air central Lacado negro / Black lacquered	UBBSAC
S Air móvil Nogal natural macizo / Natural solid walnut	UBNSAL
S Air móvil Lacado negro / Black lacquered	UBBSAL
S Fix central Nogal natural macizo / Natural solid walnut	UBNSFC
S Fix central Lacado negro / Black lacquered	UBBSFC
S Fix esquina Nogal natural macizo / Natural solid walnut	UBNSFL
S Fix esquina Lacado negro / Black lacquered	UBBSFL
S Fix frontal Nogal natural macizo / Natural solid walnut	UBNSFE
S Fix frontal Lacado negro / Black lacquered	UBBSFE

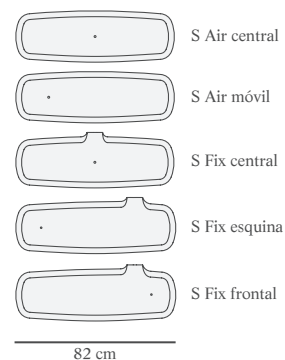

M Central Nogal natural macizo / Natural solid walnut	UBNMC
M Central Lacado negro / Black lacquered	UBBMC
M Lateral Nogal natural macizo / Natural solid walnut	UBNML
M Lateral Lacado negro / Black lacquered	UBBML

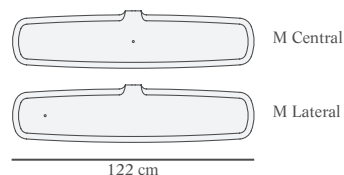

## ESCRITORIO Desk

Escritorio modular, formado por un sobre y dos patas de 70 cm, donde a partir de un eje se instalan baldas a derecha e izquierda, alternando baldas fijas a pared y libres.  
 Modular desk, formed by a desk-top, two legs of 70 cm and a central axis in which you can install alternately shelves fixed to the wall or floating shelves to the right or to the left.

Fabricado en España de forma artesanal con madera maciza de nogal.\*  
 Manufactured in Spain following artisanal methods with natural solid walnut.\*

\*Opción chapado nogal natural o fresno teñido negro.  
 \* Optional in natural walnut or black stained ash veneered.

### ESPECIFICACIONES SPECIFICATIONS

#### BALDA E / SHELF E

Longitud / Length: 124 cm  
 Ancho / Width: from 30 cm to 50 cm  
 Grosor / Thickness: 1,8 cm

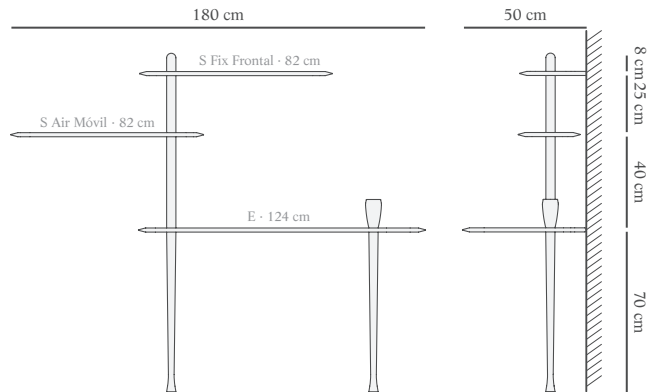
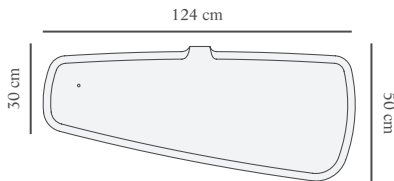

### CONFIGURACIONES SUGERIDAS SUGGESTED CONFIGURATIONS

#### Configuración 1 / Configuration 1

Baldas S: Nogal natural macizo / Shelves S: Natural solid walnut.  
 Balda E: Nogal natural macizo / Shelf E: Natural solid walnut.

#### Configuración 2 / Configuration 2\*

Baldas S: Chapado nogal natural / Shelves S: Natural walnut veneered top.  
 Balda E: Chapado nogal natural / Shelf E: Natural walnut veneered top.

#### Configuración 3 / Configuration 3\*

Baldas S: Chapado fresno teñido negro / Shelves S: Black stained ash veneered top.  
 Balda E: Chapado fresno teñido negro / Shelf E: Black stained ash veneered top.

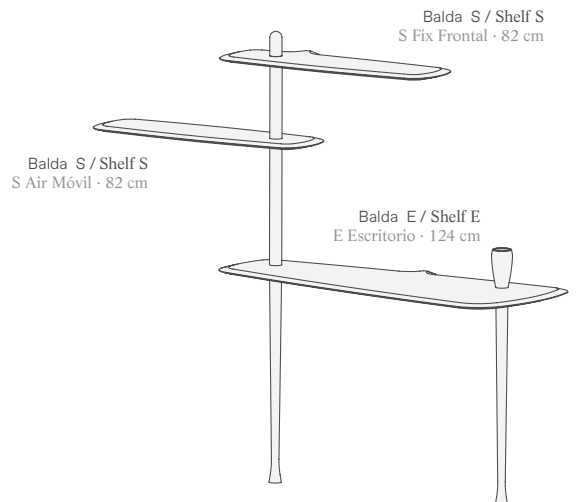

\* La configuración 2 y 3 no incluye lapicero.  
 \* Configuration 2 and 3 don't include pencil pot.

## MESA ÚNICA Long coffee table

Fabricado en España de forma artesanal.  
Sobre chapado en nogal natural o fresno teñido negro.  
Patas en nogal natural macizo o fresno teñido negro.  
Manufactured in Spain following artisanal methods.  
Natural walnut veneered or black stained ash top  
Legs in natural solid walnut or black stained ash.

### ESPECIFICACIONES SPECIFICATIONS

Altura / Height: 26,8 cm  
Ancho / Width: 42 cm  
Largo / Length: 170 cm  
Grosor de la sobre / Top thickness: 18mm

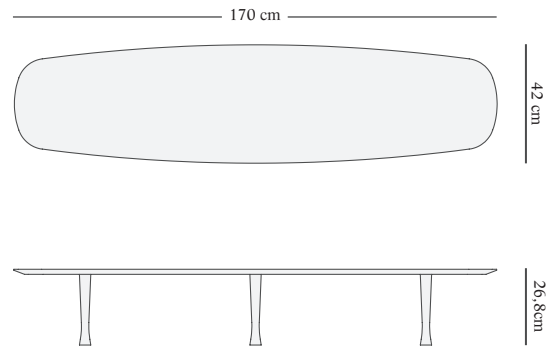

### CONFIGURACIONES SUGERIDAS SUGGESTED CONFIGURATIONS

MODEL	REF.
Mesa única · Nogal Única long coffee table · Walnut	MECN
Mesa única · Fresno teñido negro Única long coffee table · Black stained ash	MECBN

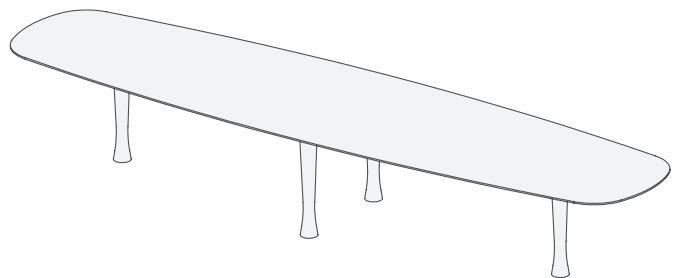

## VÉRTIGO Vértigo

MODEL	REF.
Vértigo S	PVNS
Vértigo L	PVNL

Material: Nogal natural macizo. Fabricado y pulido a mano.  
 Material: Natural solid walnut. Manufactured and polished by hand.

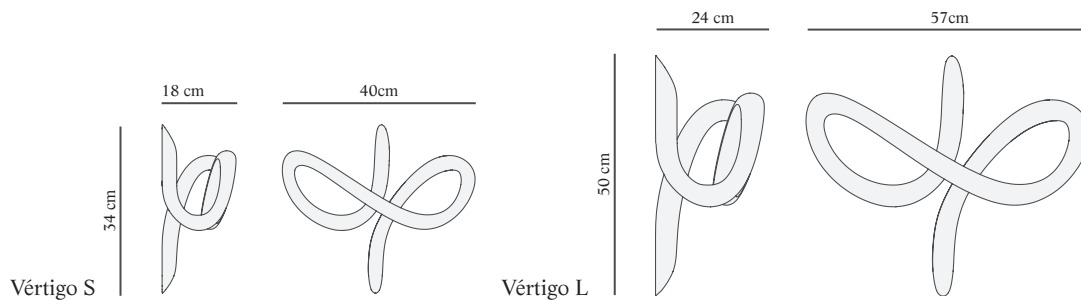

## PEONZA Spinning top

MODEL	REF.
Peonza fresno-nogal Ash-walnut Spinning top	PEOFN

Cuerpo en nogal natural macizo y fresno natural macizo.  
 Espejo acabado bronce.  
 Detalles en latón pulido.  
 Fabricado y pulido a mano.  
 Body in solid natural walnut and solid natural ash.  
 Mirror finished bronze.  
 Details in polished brass.  
 Manufactured and polished by hand.

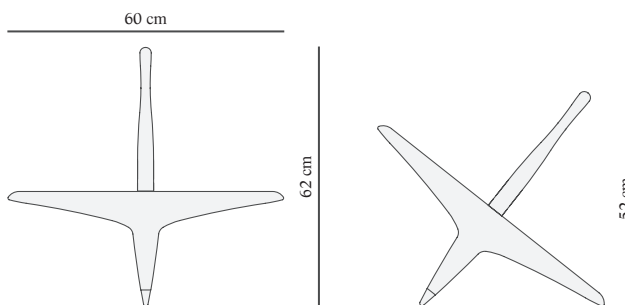

## MESA MIXTA DÚO Mixta Duo Coffee Table

Sobres: Mármol o chapado nogal natural.

Estructura: Madera de nogal natural.

Top: Natural walnut veneered or marble.

Structure: Natural solid walnut.

Mármoles: Emperador, Sahara Noir y Calacatta Gold.

Marbles: Emperador, Sahara Noir and Calacatta Gold.

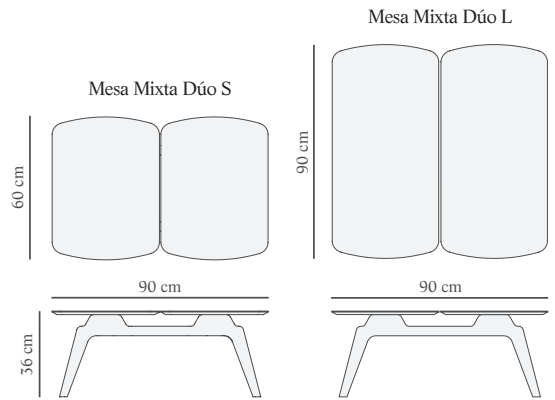

### CONFIGURACIONES / CONFIGURATIONS

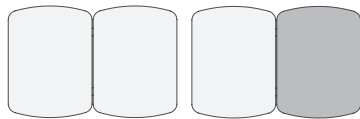

2 S Nogal/Walnut  
ref: MIDSNN

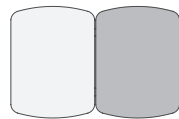

1 S Nogal/Walnut  
1 S Mármol/Marble  
ref: MIDSNE

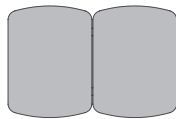

2 S Mármol/Marble  
ref: MIDSEE



2 L Nogal/Walnut  
ref: MIDLNN



1 L Nogal/Walnut  
1 L Mármol/Marble  
ref: MIDLNE



2 L Mármol/Marble  
ref: MIDLEE

## MESA MIXTA TRÍO Mixta Trio Coffee Table

Sobres: Mármol o chapado nogal natural.

Estructura: Madera de nogal natural.

Top: Natural walnut veneered or marble.

Structure: Natural solid walnut.

Mármoles: Emperador, Sahara Noir y Calacatta Gold.

Marbles: Emperador, Sahara Noir and Calacatta Gold.

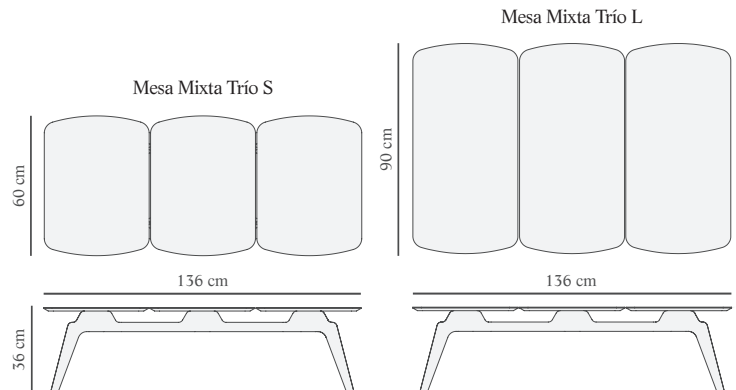

### CONFIGURACIONES / CONFIGURATIONS



3 S Nogal/Walnut  
ref: MITSNNN



2 S Nogal/Walnut  
1 S Mármol/Marble  
ref: MITSNNE



1 S Nogal/Walnut  
2 S Mármol/Marble  
ref: MITSNEE

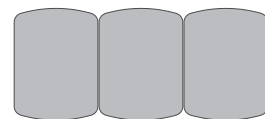

3 S Mármol/Marble  
ref: MITSEE

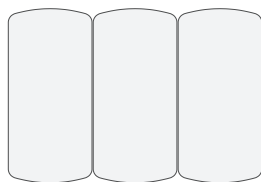

3 L Nogal/Walnut  
ref: MITLNNN

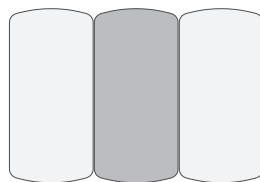

2 L Nogal/Walnut  
1 L Mármol/Marble  
ref: MITLNNE

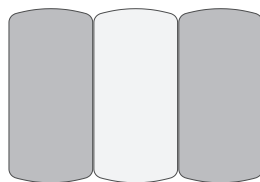

1 L Nogal/Walnut  
2 L Mármol/Marble  
ref: MITLNEE

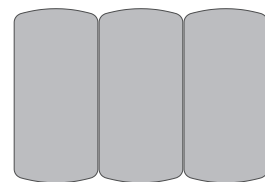

3 L Mármol/Marble  
ref: MITLEEE

## COLECCIÓN MOMENTOS/ MOMENTOS COLLECTION

Model	Weight	Dimensions (cm)	Volumetric weight
Recibidor	12,0 kg / 19,5 kg	54 x 95 x 13	13,3 kg
Tocador	12,0 kg / 19,5 kg	54 x 95 x 13	13,3 kg
Puf	10,5 kg	39 x 61 x 50	23,8 kg
Bar	16,5 kg	54 x 95 x 13	13,3 kg
Champagnera	7,0 kg	32 x 29 x 28	5,2 kg
Galán M	9,0 kg	48 x 123 x 12	14,1 kg
Galán W	10,0 kg	48 x 123 x 12	14,1 kg
Toallero	8,6 kg	48 x 123 x 12	14,1 kg
Espejo de pared	13,1 kg	59 x 144 x 11	18,7 kg
Espejo de pie	19,6 kg	59 x 144 x 11	18,7 kg
Consola	7,5 kg / 15 kg	54 x 95 x 7	7,2 kg
Mesita S	4,2 kg	40 x 60 x 7	3,4 kg
Mesita M	7,0 kg / 14,5 kg	54 x 95 x 7	7,2 kg
Vaivén	7,5 kg	55 x 53 x 19	10,6 kg
Mixta patas	6 kg	137 x 45 x 18	22,2 kg
Mixta Sobre S Nogal/Walnut	4,5 kg	71 x 55 x 8	6,3 kg
Mixta Sobre S Mármol/Marble	11,5 kg	71 x 55 x 8	6,3 kg
Mixta Sobre L Nogal/Marble	6,4 kg	101 x 55 x 8	8,9 kg
Mixta Sobre L Mármol/Marble	16,2 kg	101 x 55 x 8	8,9 kg

## COLECCIÓN ÚNICA / UNICA COLLECTION

Model	Weight	Dimensions (cm)	Volumetric weight
Balda S / S Shelf	3,0 kg	35 x 90 x 7	4,4 kg
Balda M / M Shelf	4,3 kg	35 x 130 x 7	6,4 kg
Balda E / E Shelf	7,0 kg	58 x 132 x 7	10,7 kg
Mesa Única	13,5 kg	48 x 186 x 11	19,6 kg

## COLECCIÓN ESCULTURA / SCULPTURE COLLECTION

Model	Weight	Dimensions (cm)	Volumetric weight
Vértigo L	8,4 kg	40 x 78 x 63	39,4 kg
Vértigo S	4,6 kg	39 x 61 x 50	23,8 kg
Peonza	13,0 kg	80 x 80 x 16	20,5 kg

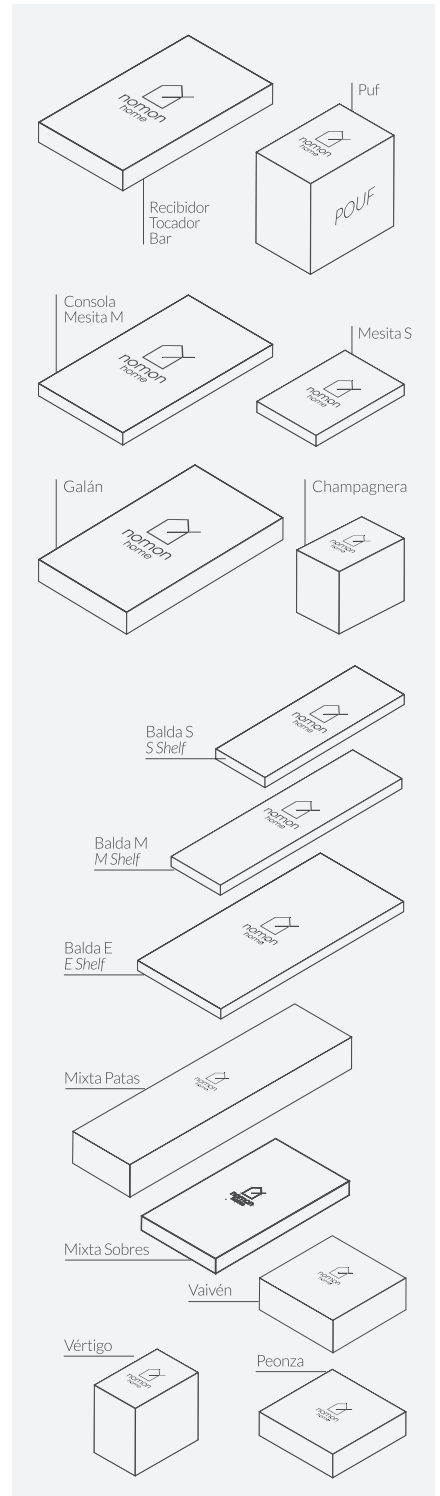



## CONTACT

www.nomon.es  
www.nomonhome.com

Spain  
T. +34 933 186 585 ext. 2  
info@nomon.es

Export  
T. +34 933 186 585 ext. 3  
export@nomon.es

Technical service  
Servicio técnico  
T. +34 933 186 585 ext. 1  
produccion@nomon.es

Press  
T. +34 933 186 585  
communication@nomon.es

Headquarters  
Carrer Tucumán, no 6 2nd floor  
08030 Barcelona  
T. +34 933 186 585

Showroom  
Passatge Maiol, 4  
08013 Barcelona



## CREDITS

Art Direction:  
Antoni Pallejà Office

Photography:  
Marcel Juan  
Paco Deogracias  
Cualiti Studio

[www.nomonhome.com](http://www.nomonhome.com)